

# Vision Cover Lifter



Top Mount ONLY

## Assembly, Installation Instructions & Parts List

Distributed By  
  
 Essentials-SpaSupplies.com

# PARTS LIST

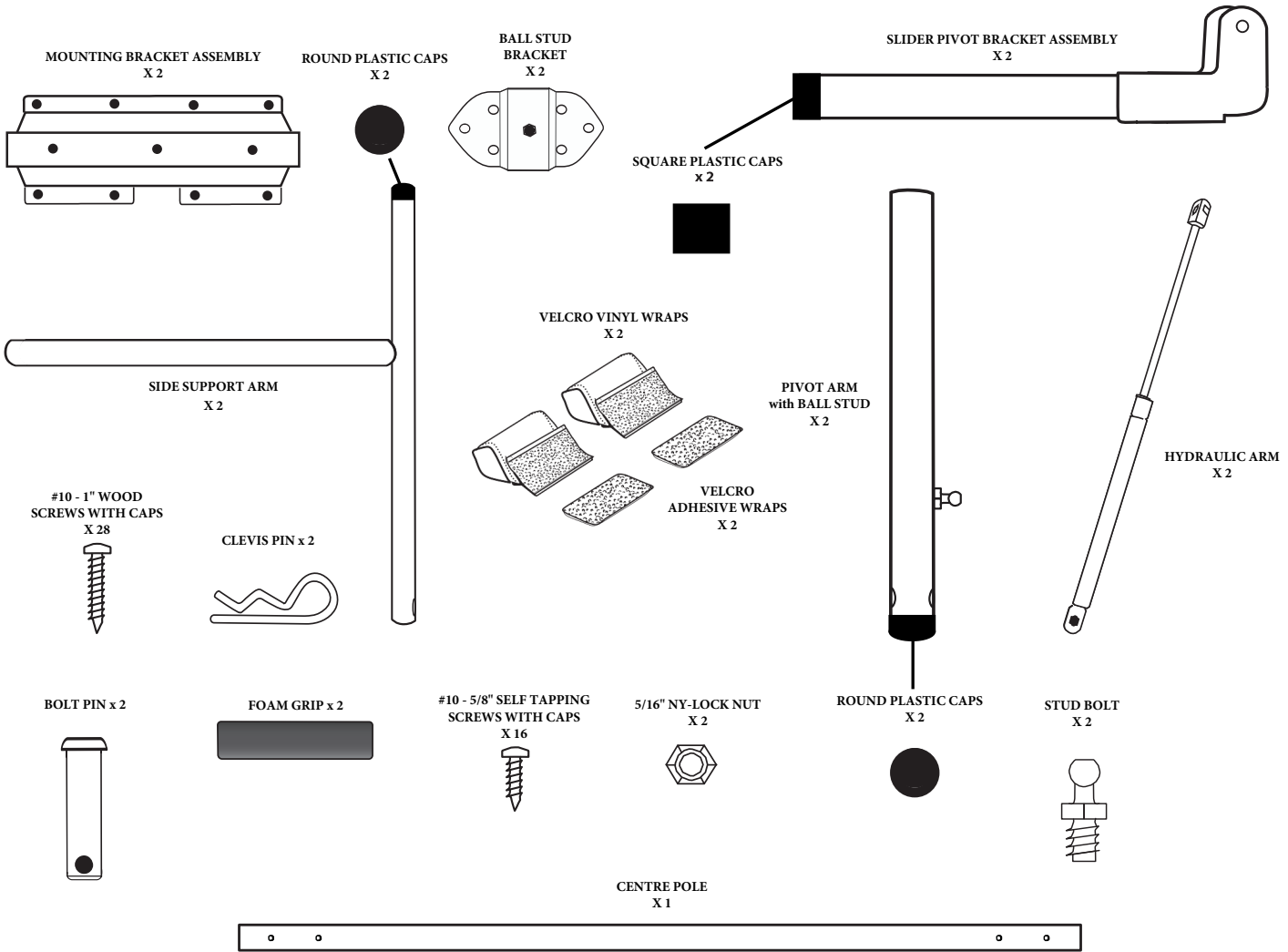

## PARTS

- Side Support Arm (x2)
- Mounting Bracket Assembly (x2)
- Slider Pivot Bracket assembly (x2)
- Hydraulic Arm (x2)
- Ball Stud Bracket (x2)
- Center Pole (x1)
- Pivot Arm with Ball Stud (x2)
- Velcro Vinyl Wraps (x2)
- Velcro Adhesive Wraps (x2)
- Round Plastic Caps (x2)

- #10 - 5/8" Self Tapping Screw (x16)
- #10 - 1" Woodscrew (x28)
- #10 Screw Caps (x48)
- 5/16" NY-Lock Nut (x2)
- Foam Grip (x2)
- Square Plastic Caps (x2)
- Round Plastic Caps (x2)
- Stud Bolt (x2)
- Bolt Pin (x2)
- Clevis Pin (x2)

## TOOLS LIST

- Phillips screwdriver
- Measuring tape
- Drill
- 1/8 drill bit
- Adjustable wrench

# VISION COVER LIFTER

## Hydraulic Mount Application of the Velcro Tape

**NOTE:** Adhesive bond strength requires a minimum of 1 hour at temperatures between 68 and 100 degrees F before applying load. This dwell time is important for achieving a firm adhesive bond before using.

Clean and dry the cover before application. You can use any cleaner that will not leave a film or oily surface. We recommend using alcohol prep pads.

Center the Velcro tape along the folding seam of the cover, allowing a minimum of 52" between each Velcro strip. Peel the tape from the backing and press firmly into place.

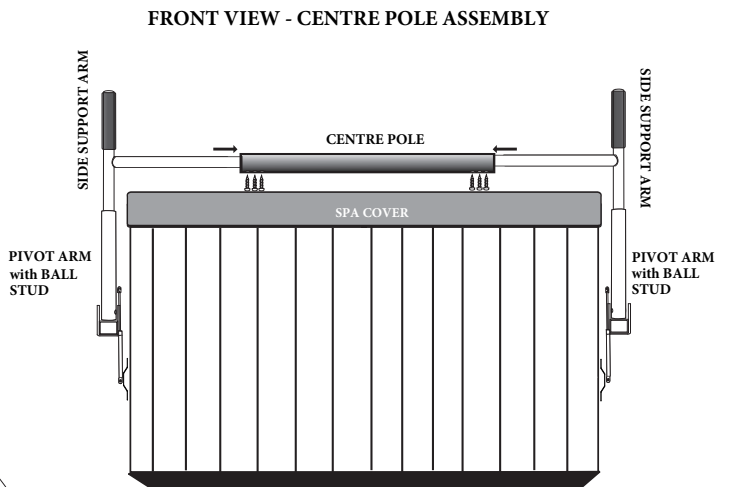
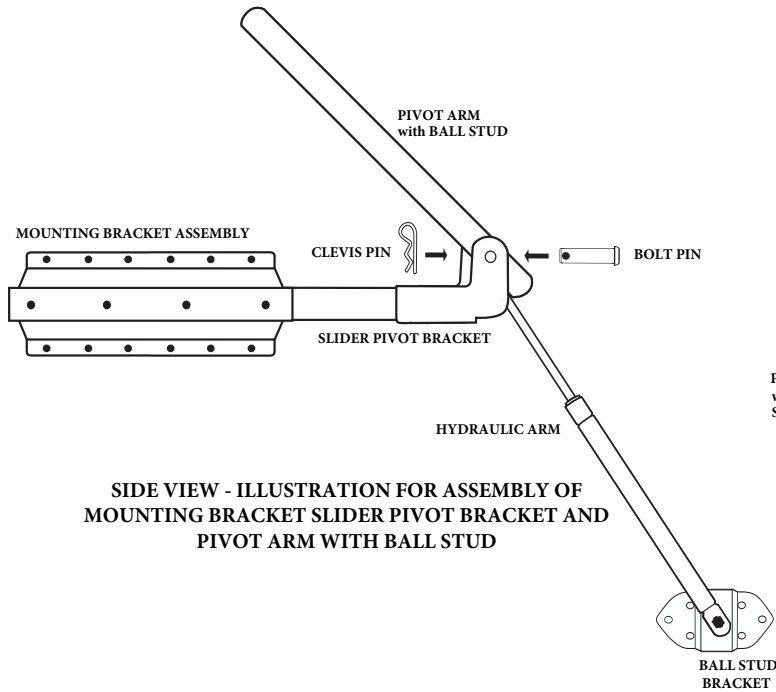
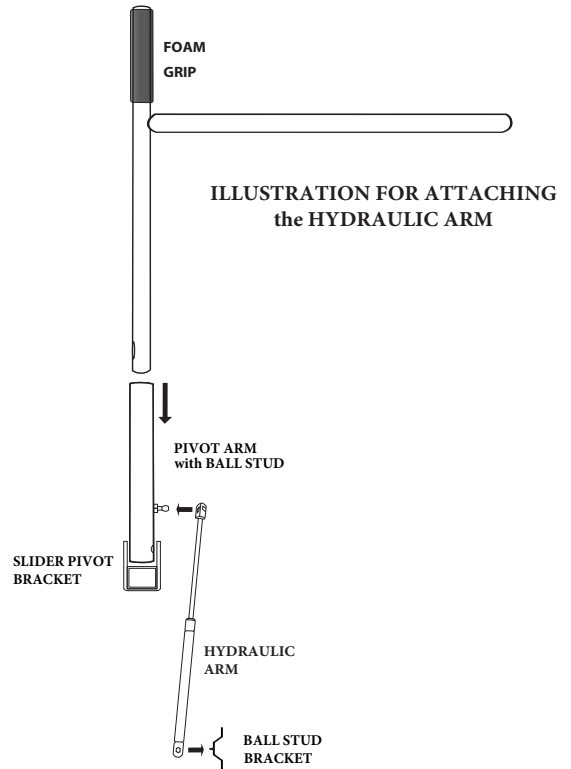
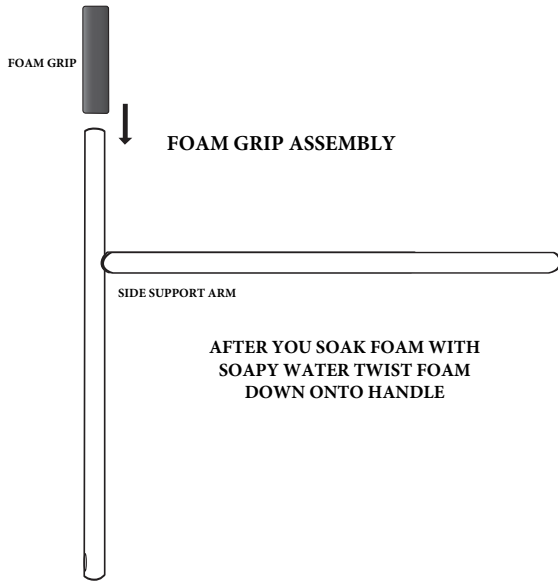

# VISION COVER LIFTER

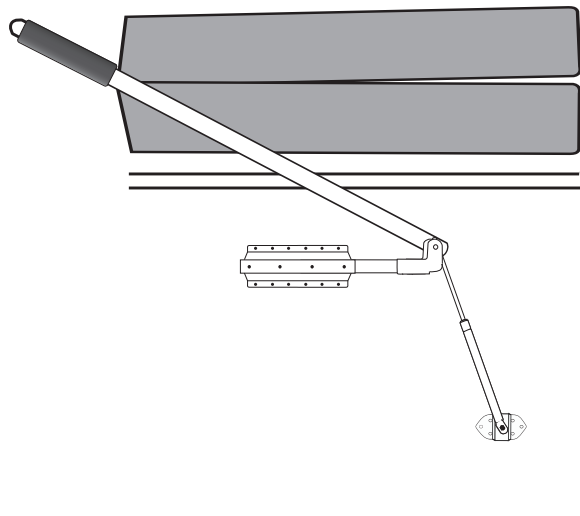

**CAUTION:**  
**DO NOT USE**  
the *UltraLift* in windy conditions.  
The spa cover may blow over  
and impact the spa user.

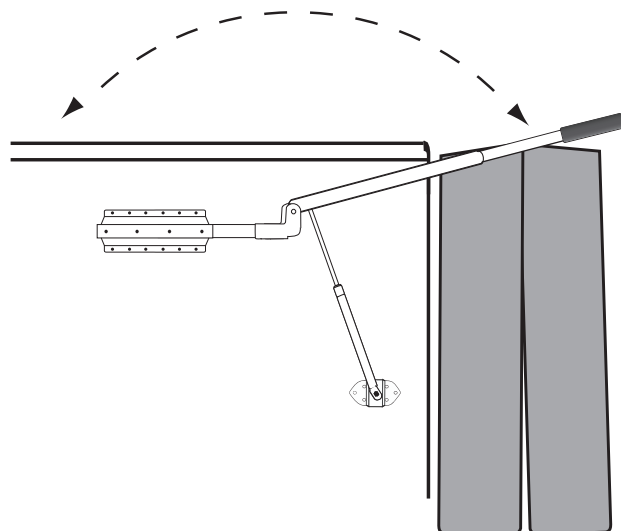
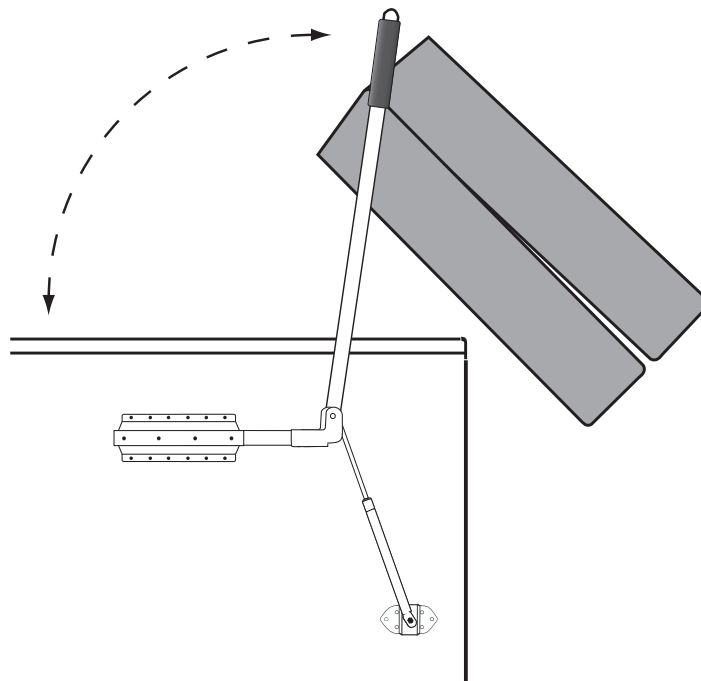

# VISION COVER LIFTER

Step 1:

Determine the mounting bracket position.....

**TO DETERMINE PIVOT LOCATION**

		<i>Cover Thickness (Inches)</i>			
		3	4	5	6
<i>Spa Cover Size (Inches)</i>	70	14.5	13.5	12.5	11.5
	72	15	14	13	12
	74	15.5	14.5	13.5	12.5
	76	16	15	14	13
	78	16.5	15.5	14.5	13.5
	80	17	16	15	14
	82	17.5	16.5	15.5	14.5

*For spas up to 7 feet  
80 lb Gas spring*

<i>Spa Cover Size (Inches)</i>	84	18	17	16	15
	86	18.5	17.5	16.5	15.5
	88	19	18	17	16
	90	19.5	18.5	17.5	16.5
	92	20	19	18	17
	94	20.5	19.5	18.5	17.5
	96	21	20	19	18
	98	21.5	20.5	19.5	18.5
	100	22	21	20	19

*For spas over 7 feet  
110 lb gas  
spring*

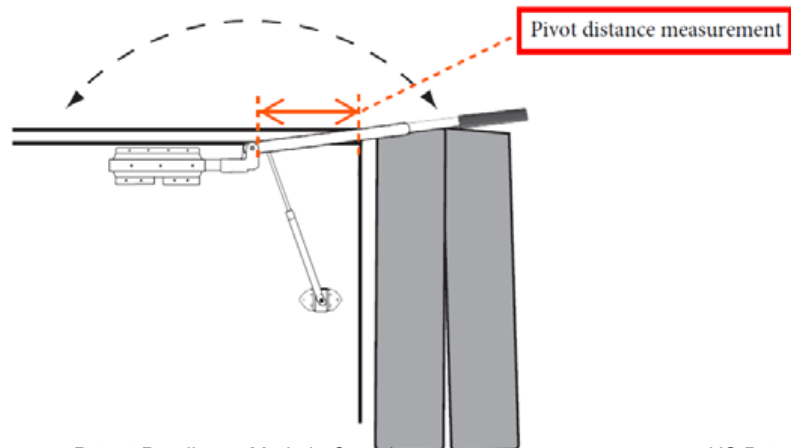

# VISION COVER LIFTER

## Step 2:

Mount the bracket close to the top of the spa, using the longer woodscrews, as shown in the illustration. Slide the slider pivot bracket into the mounting bracket, to the pre-determined position calculated in step 1 and secure to the mounting bracket using the self-tapping screws. Repeat on the other side of the spa.

## Step 3:

With the cover in the closed position on the spa, place the centre pole in the middle of the cover along the seam. Slide the longer side of each support arm into both ends of the centre pole. Ensure the cover hook, as shown in the pre-assembly instructions, is on the side support arm and will slide between the cover seam and the middle of the cover.

## Step 4:

Slide the pivot arm over the side support arm, so that the ball stud faces the side of the spa. Connect the bottom of the round pivot arm to the slider pivot bracket using the bolt pin and clevis pin.

## Step 5:

Ensure the assembly is square and the centre pole sits 1" from the cover's centre seam.\*\*, on the lifter side. We recommend rotating the centre pole so that the screws are inserted horizontally, and secure the centre pole and the pivot arms to the corner support arms using self-tapping screws.

## Step 6:

Slide the spring-loaded end piece of the hydraulic arm over the ball stud on the pivot arm. Attach the opposite end over the ball stud on the smaller mounting bracket.

## Step 7:

To find the location of the smaller pivot bracket, the pivot arm must be in line with the hydraulic arm. This may require lifting the cover, to achieve the optimal position. The smaller bracket should be placed at the edge of the radius corner to ensure the bracket is secured into the tub frame, which is usually found at the end of the side panel.



#### THE WARRANTY:

SMP Specialty Metal Products Inc. warrants to you (the original purchaser) for the stated warranty term of FIVE YEARS (60 Months) from the original date of purchase, to be free from defects in material and workmanship.

UltraLift Cover Lifters will be free from defects in materials or workmanship that would cause the lifter to be inoperable in normal working conditions. Any claim made within these terms for Five years from the date of purchase will be repaired or replaced at the option of the Manufacturer.

This is a 100% Non-Prorated Warranty on all parts for the full 5 years. Only parts excluded from the warranty are the gas springs which include a 100% One Year Warranty.

#### EXCLUSIONS TO WARRANTY

- Lifter has been subjected to alteration, misuse or repairs by anyone other than an authorized representative of the Manufacturer, unless written approval is provided
- Damage caused by improper installation or during transportation from the seller to the purchaser
- Any damage resulting from any misuse, abuse, negligence, accident or alteration, environmental, or use during high winds

The warranty covers the operational use of the lifter but does not cover scratches, abrasions, rusting or any defects to the finish of the material caused by or resulting from the exposure to the environmental factors; i.e. sun, rain, chemicals or any defects resulting from normal fading or minor deterioration.

The warranty does not cover damage resulting from abuse or accidents, including but not limited to the following damage:

- Use of abrasive or unapproved cleaners that could cause surface damage
- Subjection to solvents or other chemicals which could deteriorate painted surfaces
- Use for any other purpose than as a Spa or Hot tub cover lifter

#### MAKING A CLAIM:

To make a warranty claim; in the event of a defect covered by this warranty for UltraLift, contact the original retail seller and provide original purchase receipt, any photo(s) clearly showing the defect(s) and an explanation. **NO RETURNS OF MERCHANDISE WILL BE ACCEPTED UNTIL A "RETURN AUTHORIZATION NUMBER" HAS BEEN ISSUED.**

The lifter will be repaired or replaced at the discretion of the Manufacturer. If necessary, the purchaser is responsible to ship any said parts back to the manufacturer. The warranty includes all Labor costs performed at the manufacturer's facility but not labor in the field. SMP will cover the cost(s) to repair and/or replacement of the items back to the retailer or seller.

#### FREIGHT DAMAGE:

Any materials damaged in freight will be replaced by SMP Specialty Metal Products provided the purchaser files the appropriate claims form with the carrier, and submits copies to the manufacturer within five (5) business days of receiving the damaged merchandise. All claims should also be reported to the seller.

#### Consequential Damages:

SMP Specialty Metal Products Inc. will not be liable for any loss, expense, or damage other than to UltraLift, that may result from a defect in materials or workmanship. This warranty does not cover incidental damages including damage to property or injury arising from the use or inability to use this product. Manufacturer or Seller shall in no event be liable for any amount in excess of the original purchased amount. (Some Provinces / States do not allow the exclusion or limitation of incidental or consequential damages, so the above mentioned limitation may not apply to you).

It is important that you report to the Retailer from whom you purchased UltraLift, any defects as soon as they are detected. If it is impractical to report any defects to the Retailer, Contact **SMP Specialty Metal Products Inc. 326 Watline Avenue, Mississauga, Ontario Canada, L4Z 1X2; Phone: 1-800-597-1343, Email: info@theultralift.com**